

PROMO **Klainod**[®]

FRESE

MANDRINI

ACCESSORI

TASTATORI



FRESE

Metallo Duro Integrale - DIN 6527L - Serie Normale

F2NCTF

(Frese a testa piana - 2 tagli)



F3NCTF

(Frese a testa piana - 3 tagli)



F4NCTF

(Frese a testa piana - 4 tagli)

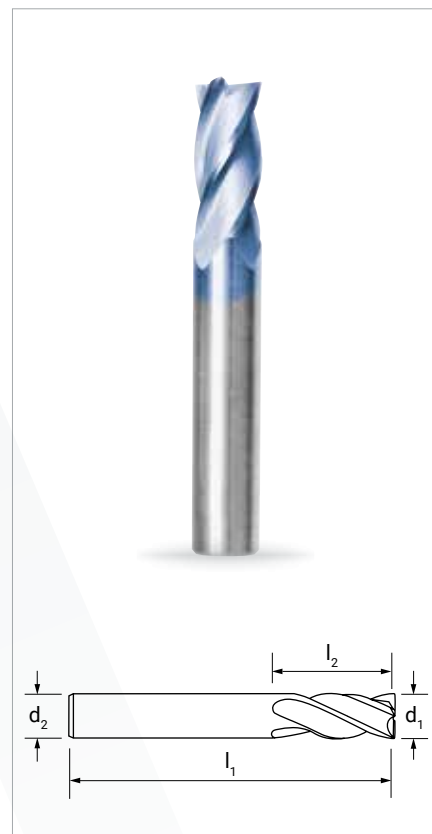

2

d ₁ (e8)	l ₁	l ₂	d ₂	Z	€
------------------------	----------------	----------------	----------------	---	---

2	50	6	4	2	6,79
3	50	8	4	2	6,79
4	50	11	4	2	6,79
5	50	13	6	2	9,15
6	50	16	6	2	9,90
8	60	20	8	2	18,30
10	75	25	10	2	28,05
12	75	30	12	2	40,30
14	83	40	14	2	61,10
16	92	40	16	2	77,50

Esempio d'ordine: F2NCTF 2

d ₁ (e8)	l ₁	l ₂	d ₂	Z	€
------------------------	----------------	----------------	----------------	---	---

2	50	6	4	3	6,79
3	50	8	4	3	6,79
4	50	11	4	3	6,79
5	50	13	6	3	9,15
6	50	16	6	3	9,90
8	60	20	8	3	18,30
10	75	25	10	3	28,05
12	75	30	12	3	40,30
14	83	40	14	3	61,10
16	92	40	16	3	77,50

Esempio d'ordine: F3NCTF 2

d ₁ (e8)	l ₁	l ₂	d ₂	Z	€
------------------------	----------------	----------------	----------------	---	---

2	50	6	4	4	6,79
3	50	8	4	4	6,79
4	50	11	4	4	6,79
5	50	13	6	4	9,15
6	50	16	6	4	9,90
8	60	20	8	4	18,30
10	75	25	10	4	28,05
12	75	30	12	4	40,30
14	83	40	14	4	61,10
16	92	40	16	4	77,50

Esempio d'ordine: F4NCTF 2

FRESE

Metallo Duro Integrale - DIN 6527L - Serie Normale



F4VCTF

(Frese a testa piana - 4 tagli)



d_1 (e8)	l_1	l_2	d_2	Z	€
3	50	8	6	4	8,14
4	50	11	6	4	8,14
5	50	13	6	4	10,98
6	50	16	6	4	11,89
8	60	20	8	4	21,95
10	72	22	10	4	33,65
12	75	26	12	4	48,40
16	100	36	16	4	93,00

Esempio d'ordine: F4VCTF 3

F2NSTF

(Frese sferiche - 2 tagli)



d_1 (h10)	l_1	l_2	d_2	R	Z	€
2	50	4	4	1	2	10,56
3	50	6	4	1,5	2	10,56
4	50	8	4	2	2	10,56
5	50	10	6	2,5	2	13,16
6	50	12	6	3	2	13,16
8	60	16	8	4	2	23,00
10	75	20	10	5	2	34,00
12	75	24	12	6	2	49,00
14	83	28	14	7	2	70,40
16	92	32	16	8	2	86,00

Esempio d'ordine: F2NSTF 2

F4NSTF

(Frese sferiche - 4 tagli)



d_1 (h10)	l_1	l_2	d_2	R	Z	€
3	50	6	4	1,5	4	10,56
4	50	8	4	2	4	10,56
5	50	10	6	2,5	4	13,16
6	50	12	6	3	4	13,16
8	60	16	8	4	4	23,00
10	75	20	10	5	4	34,00
12	75	24	12	6	4	49,00
14	83	28	14	7	4	70,40
16	92	32	16	8	4	86,00

Esempio d'ordine: F4NSTF 3

MANDRINI

a Serraggio Idraulico

E-ISOID

(SK - DIN 69871)

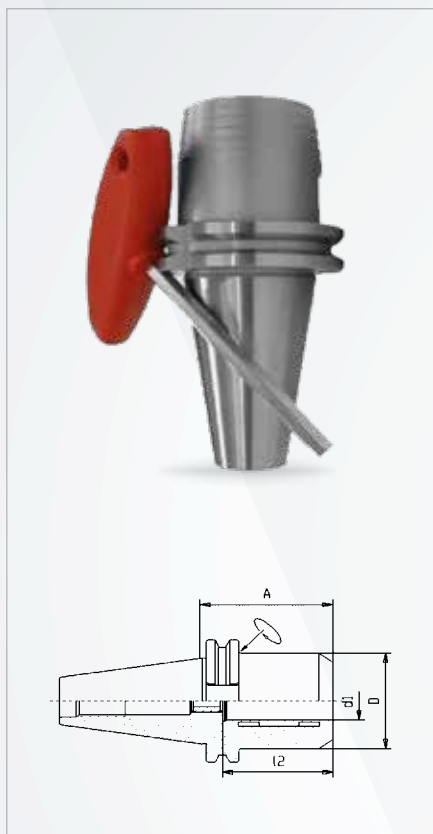

E-BTID

(MAS 403 - BT)

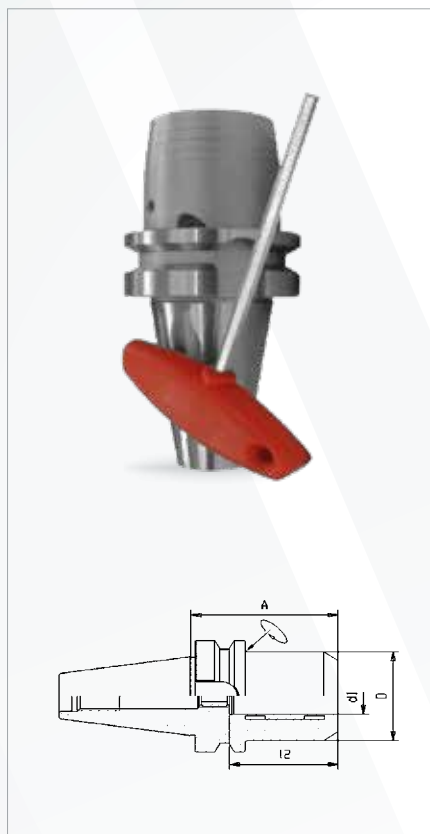

E-HSKID

(HSK - DIN 69893)



4

SK x d1 x A	L2	D	€
-------------	----	---	---

40	6	75	38	26	152,00
40	8	75	38	28	152,00
40	10	75	40	30	140,50
40	12	80	45	32	152,00
40	16	85	50	38	152,00
40	20	90	52	42	140,50
40	25	110	59	53	152,00
40	32	115	60	60	152,00

Esempio d'ordine: EISOID 40x6x75

SK x d1 x A	L	D	€
-------------	---	---	---

40	6	80	38	26	152,00
40	8	80	38	28	152,00
40	10	80	40	30	140,50
40	12	90	45	32	152,00
40	16	90	50	38	152,00
40	20	95	52	42	140,50
40	25	105	59	53	152,00
40	32	110	60	60	152,00

Esempio d'ordine: EBTID 40x6x80

HSK x d1 x A	L	D	€
--------------	---	---	---

63	6	70	112	42	173,50
63	8	70	112	42	173,50
63	10	80	117	42	165,00
63	12	85	122	42	173,50
63	16	90	127	50	173,50
63	20	90	132	50	165,00
63	25	120	137	-	181,50
63	32	125	157	-	181,50

Esempio d'ordine: EHSKID 63x6x70

ACCESSORI

Bussole di riduzione

E-BSID

(BUSSOLE DI RIDUZIONE A TENUTA STAGNA)

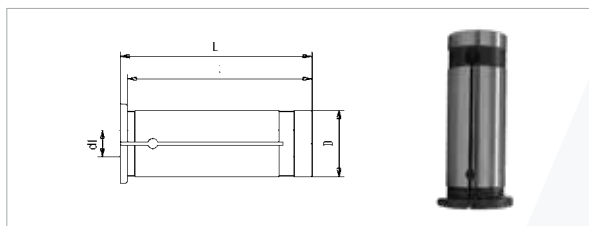

Codice d'ordine	D	d1	L	€
EBSID 20X6	20	6	57	46,20
EBSID 20X8	20	8	57	46,20
EBSID 20X10	20	10	57	46,20
EBSID 20X12	20	12	57	46,20
EBSID 20X16	20	16	57	46,20
EBSID 32X10	32	10	65	56,10
EBSID 32X12	32	12	65	56,10
EBSID 32X14	32	14	65	56,10
EBSID 32X16	32	16	65	56,10
EBSID 32X18	32	18	65	56,10
EBSID 32X20	32	20	65	56,10
EBSID 32X25	32	25	65	56,10

Esempio d'ordine: EBSID 20X6

MANDRINI

Portapinze ER DIN 6499

E-ISOER

(SK - DIN 69871)

E-BTER

(MAS 403 - BT)

E-HSKER

(HSK - DIN 69893)

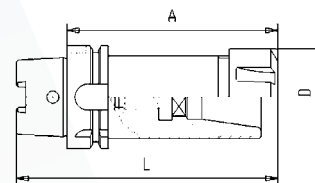
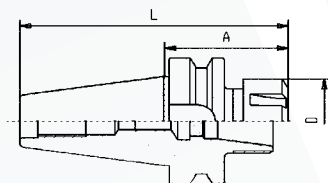
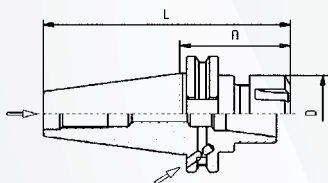

6

SK x ER x A	L	D	€
40 16 63	132	32	31,10
40 25 60	129	42	31,10
40 32 70	139	50	31,10
50 25 60	162	42	75,40
50 32 70	172	50	59,40
50 40 80	182	63	59,40

Esempio d'ordine: EISOER 40x16x63

SK x ER x A	L	D	€
40 16 60	118	32	31,10
40 25 60	126	42	31,10
40 32 60	126	50	34,30
50 32 70	172	50	68,80
50 40 80	182	63	68,80

Esempio d'ordine: EBTER 40x16x60

HSK x ER x A	L	D	€
63 16 100	132	28	57,80
63 25 100	132	42	57,80
63 32 100	132	50	57,80
63 40 120	152	63	62,70

Esempio d'ordine: EHSKER 63x16x100

ACCESSORI

Pinze ER DIN 6499

PZER

(ER 16-25-32-40 - DIN 6499)

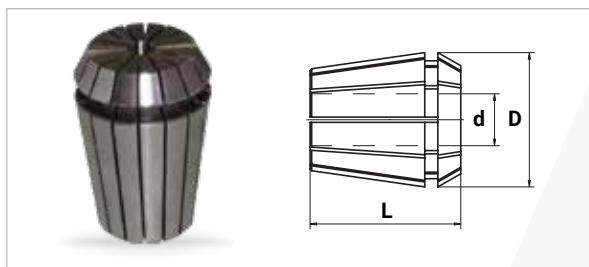

ER x d	D	L	d (ER)	€
--------	---	---	--------	---

ER 16

16	1	17	27.5	1 ÷ 0.5	5,93
16	2	17	27.5	2 ÷ 1	5,93
16	3	17	27.5	3 ÷ 2	5,93
16	4	17	27.5	4 ÷ 3	5,93
16	5	17	27.5	5 ÷ 4	5,93
16	6	17	27.5	6 ÷ 5	5,93
16	7	17	27.5	7 ÷ 6	5,93
16	8	17	27.5	8 ÷ 7	5,93
16	9	17	27.5	9 ÷ 8	5,93
16	10	17	27.5	10 ÷ 9	5,93

ER 25

25	2	26	34	2 ÷ 1.5	6,24
25	3	26	34	3 ÷ 2	6,24
25	4	26	34	4 ÷ 3	6,24
25	5	26	34	5 ÷ 4	6,24
25	6	26	34	6 ÷ 5	6,24
25	7	26	34	7 ÷ 6	6,24
25	8	26	34	8 ÷ 7	6,24
25	9	26	34	9 ÷ 8	6,24
25	10	26	34	10 ÷ 9	6,24
25	11	26	34	11 ÷ 10	6,24
25	12	26	34	12 ÷ 11	6,24
25	13	26	34	13 ÷ 12	6,24
25	14	26	34	14 ÷ 13	6,24

ER x d	D	L	d (ER)	€
--------	---	---	--------	---

ER 25

25	15	26	34	15 ÷ 14	6,24
25	16	26	34	16 ÷ 15	6,24

ER 32

32	3	33	40	3 ÷ 2	6,24
32	4	33	40	4 ÷ 3	6,24
32	5	33	40	5 ÷ 4	6,24
32	6	33	40	6 ÷ 5	6,24
32	7	33	40	7 ÷ 6	6,24
32	8	33	40	8 ÷ 7	6,24
32	9	33	40	9 ÷ 8	6,24
32	10	33	40	10 ÷ 9	6,24
32	11	33	40	11 ÷ 10	6,24
32	12	33	40	12 ÷ 11	6,24
32	13	33	40	13 ÷ 12	6,24
32	14	33	40	14 ÷ 13	6,24
32	15	33	40	15 ÷ 14	6,24
32	16	33	40	16 ÷ 15	6,24

ER 40

40	3	41	46	3 ÷ 2	7,50
40	4	41	46	4 ÷ 3	7,50
40	5	41	46	5 ÷ 4	7,50
40	6	41	46	6 ÷ 5	7,50
40	7	41	46	7 ÷ 6	7,50
40	8	41	46	8 ÷ 7	7,50
40	9	41	46	9 ÷ 8	7,50
40	10	41	46	10 ÷ 9	7,50
40	11	41	46	11 ÷ 10	7,50
40	12	41	46	12 ÷ 11	7,50
40	13	41	46	13 ÷ 12	7,50
40	14	41	46	14 ÷ 13	7,50
40	15	41	46	15 ÷ 14	7,50
40	16	41	46	16 ÷ 15	7,50

La gamma prosegue >>

MANDRINI

Portafrese Weldon

E-ISOWE

(SK - DIN 69871)

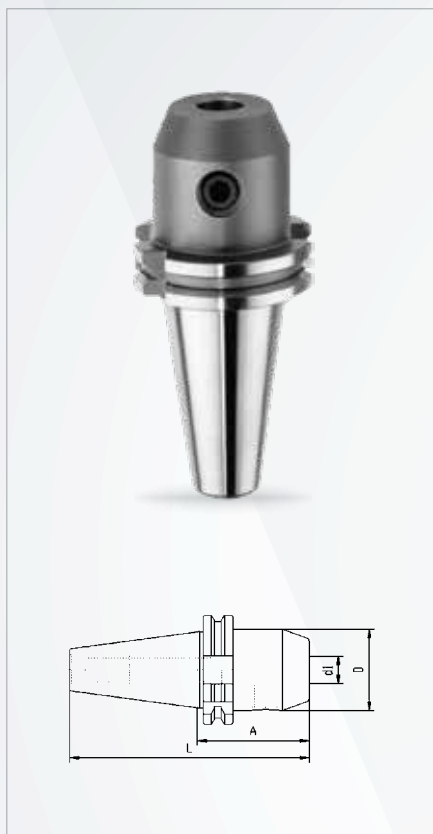

SK x d1 x A	L	D	€
40 6 50	118	25	28,85
40 8 50	118	28	26,95
40 10 50	118	35	26,95
40 12 50	118	42	26,95

Esempio d'ordine: EISOWE 40x6x50

E-BTWE

(MAS 403 - BT)



SK x d1 x A	L	D	€
40 6 50	116	25	28,85
40 8 50	116	28	26,95
40 10 63	129	35	26,95
40 12 63	129	42	26,95

Esempio d'ordine: EBTWE 40x6x50

E-HSKWE

(HSK - DIN 69893)



HSK x d1 x A	L	D	€
63 6 65	97	25	48,50
63 8 65	97	28	47,70
63 10 65	97	35	47,40
63 12 80	112	42	47,70

Esempio d'ordine: EHSKWE 63x6x65

MANDRINI

Portafrese Whistle Notch



E-ISOWN

(SK - DIN 69871)



E-BTWN

(MAS 403 - BT)



E-HSKWN

(HSK - DIN 69893)



SK x d1 x A	L	D	€
-------------	---	---	---

40 6 50	118	25	28,85
40 8 50	118	28	26,95
40 10 50	118	35	26,95
40 12 50	118	42	26,95

Esempio d'ordine: EISOWN 40x6x50

SK x d1 x A	L	D	€
-------------	---	---	---

40 6 50	116	25	28,85
40 8 50	116	28	26,95
40 10 63	129	35	26,95
40 12 63	129	42	26,95

Esempio d'ordine: EBTWN 40x6x50

HSK x d1 x A	L	D	€
--------------	---	---	---

63 6 80	112	25	58,30
63 8 80	112	28	56,80
63 10 80	112	35	56,80
63 12 90	122	42	56,80

Esempio d'ordine: EHSKWN 63x6x80

MANDRINI

Portafrese Fissi

E-ISOFI

(SK - DIN 69871)

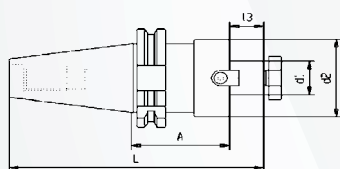

E-BTFI

(MAS 403 - BT)

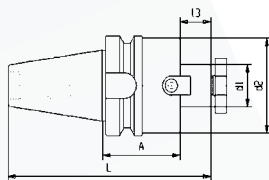

E-HSKFI

(HSK - DIN 69893)

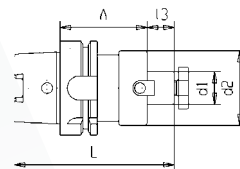

10

SK x d1 x A	d2	L	l3	€
-------------	----	---	----	---

40 16 35	44,5	121	17	25,40
40 22 35	44,5	123	19	24,75
40 27 35	44,5	125	21	25,40
40 32 55	78,0	148	24	26,55

Esempio d'ordine: EISOFI 40x16x35

SK x d1 x A	d2	L	l3	€
-------------	----	---	----	---

40 16 45	44	128	17	27,95
40 22 45	50	130	19	27,25
40 27 45	50	132	21	27,95
40 32 50	78	140	24	29,20

Esempio d'ordine: EBTFI 40x16x45

HSK x d1 x A	d2	L	l3	€
--------------	----	---	----	---

63 16 45	17	44	99	61,80
63 22 50	19	48	101	63,20
63 27 60	21	60	113	65,00
63 32 60	24	78	116	67,80

Esempio d'ordine: EHSKFI 63x16x45

TASTATORE 3D

Nuova Generazione - Universale



TTRNG

(Tastatore 3D "Nuova Generazione")

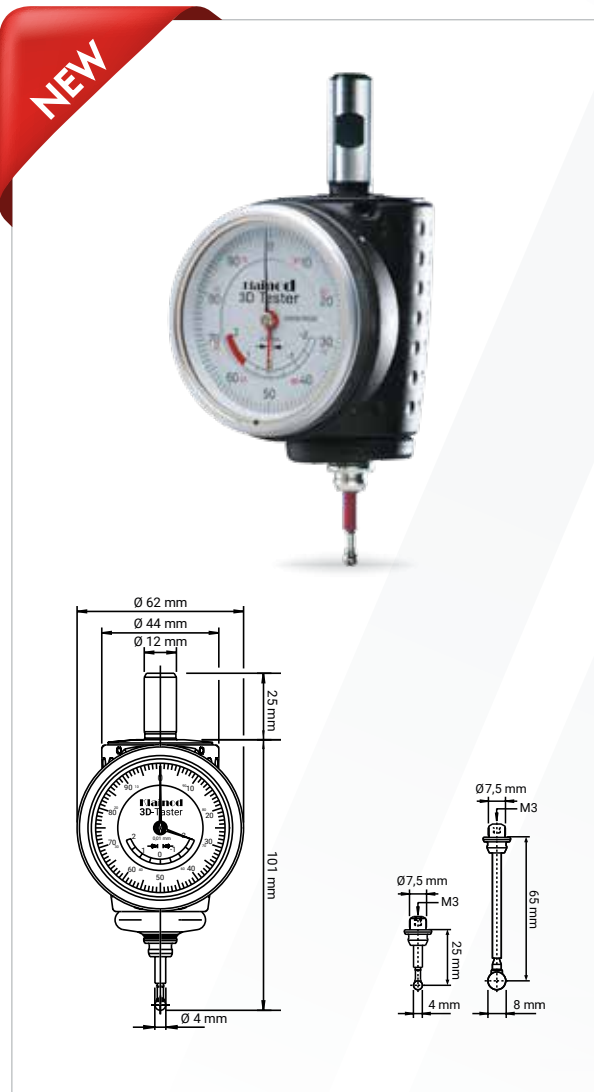

TTRU

(Tastatore 3D Universale)

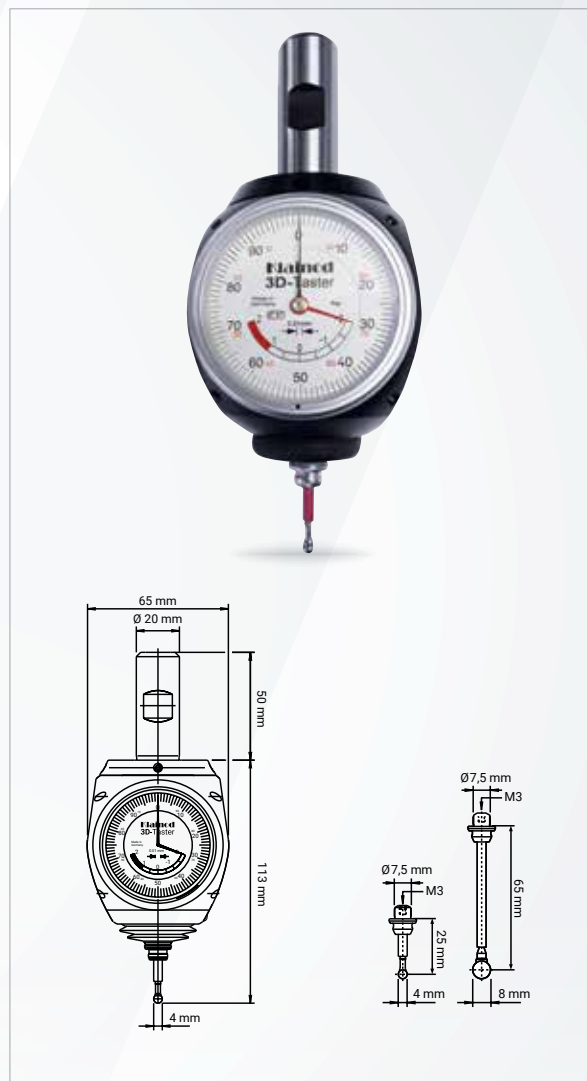

Codice d'ordine	Prezzi a richiesta	€
-----------------	--------------------	---

TTRNG 12x101	Tastatore 3D N.G.	-
--------------	-------------------	---

Parti di ricambio:

TST 4x25	Astina Corta	-
TST 8x65	Astina Lunga	-

Codice d'ordine	Prezzi a richiesta	€
-----------------	--------------------	---

TTRU 20x113	Tastatore 3D U.	-
-------------	-----------------	---

Parti di ricambio:

TST 4x25	Astina Corta	-
TST 8x65	Astina Lunga	-

Klainod®



Angelo Ghezzi & C SpA

Via Privata Gorlich, 1 • 20037 Paderno Dugnano (MI) • Italy • Tel. +39 02 9189314
www.angeloghezzi.it • info@angeloghezzi.it

